

## ANT-LOCK BRAKE SYSTEM OF HYBRID CONTROL

Сунь Юйцзе

Belarusian National Technical University  
Minsk, Belarus, [313430671@qq.com](mailto:313430671@qq.com)

Anti-lock braking system (ABS) is an automobile safety system that allows the wheels on a motor vehicle to maintain tractive contact with the road surface according to driver inputs while braking, preventing the wheels from locking up (ceasing rotation) and avoiding uncontrolled skidding. It is an automated system that uses the principles of threshold braking and cadence braking which were practiced by skillful drivers with previous generation braking systems. It does this at a much faster rate and with better control than a driver could manage.

ABS generally offers improved vehicle control and decreases stopping distances on dry and slippery surfaces for many drivers; however, on loose surfaces like gravel or snow-covered pavement, ABS can significantly increase braking distance, although still improving vehicle control.

Since initial widespread use in production cars, anti-lock braking systems have been improved considerably. Recent versions not only prevent wheel lock under braking, but also electronically control the front-to-rear brake bias. This function, depending on its specific capabilities and implementation, is known as electronic brakeforce distribution (EBD), traction control system, emergency brake assist, or electronic stability control (ESC).

### 1 Theoretical ABS basics

The brake force coefficient ( $\mu_B$ ):

The brake force coefficient (adhesion) between the wheel and the carriageway determines the braking forces that can be transferred. It depends in the brake slip between the tyre and the road, and among the factors affecting it are:

- The condition of the road and the tyres
- The wheels or axle load
- The speed of the vehicle
- The temperature
- The tyre slip angle and/or the cornering force used.

The cornering force coefficient ( $\mu_s$ ):

Maintaining cornering stability is an essential requirement for the steerability of a vehicle. The cornering force coefficient decreases much more rapidly than the brake force coefficient in combination with the same brake slip.

The brake slip ( $\lambda$ ):

brake slip is the percentage ratio of vehicle speed to wheel speed.

The slip is defined by the following equation:

$$\text{brake slip } \lambda = \frac{V_F - V_R}{V_F} * 100\%$$

$V_F$  = Vehicle speed

$V_R$  = Wheel circumference speed

Explanation of the slip curves ( $\mu_B$  and  $\mu_S$ ) Fig. 1. [1].

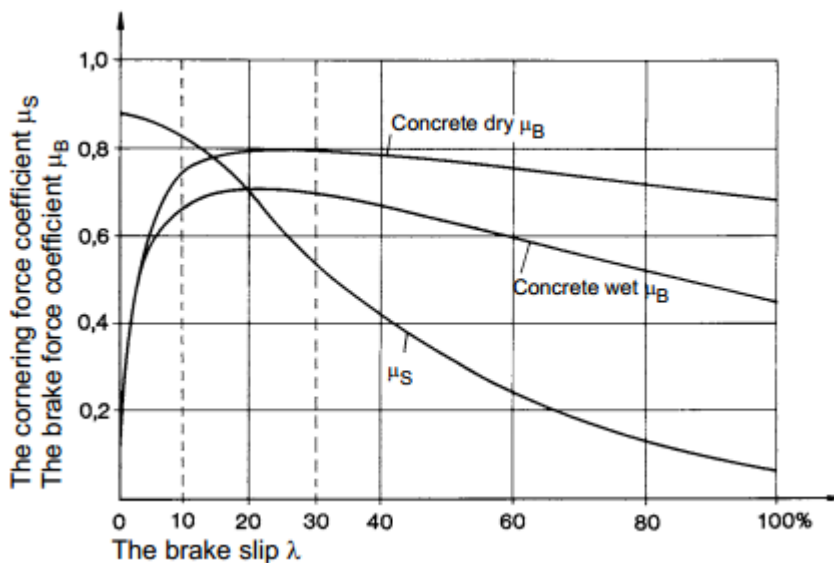

Figure 1 – Slip-friction curves for different road conditions.

This illustration shows the relationship between the brake force coefficient  $\mu_B$ , the cornering force coefficient  $\mu_S$  and the brake slip  $\lambda$  for different road conditions.

While maximum adhesion is not achieved, it is possible to increase the braking force within the “stable” range by increasing increasing the slip. In this case, there are also sufficiently large cornering forces available available to keep the vehicle steerable and therefor stable.

In the unstable range of the  $\mu$ - $\lambda$  curve (between approx. 30 and 100%) is reached due excessive braking forces, the wheels is overbraked and will lock (100% slip). The vehicle is then almost

completely unsteerable. To prevent this from happening, the ABS system regulates adhesion between 10% and 30% slip.

## 2 The primary components of the ABS braking system

- Electronic control unit (ECU) Fig. 2. [2].
- Hydraulic control unit or modulator
- Power booster & master cylinder assembly
- Wheel sensor unit Fig. 3. [3].

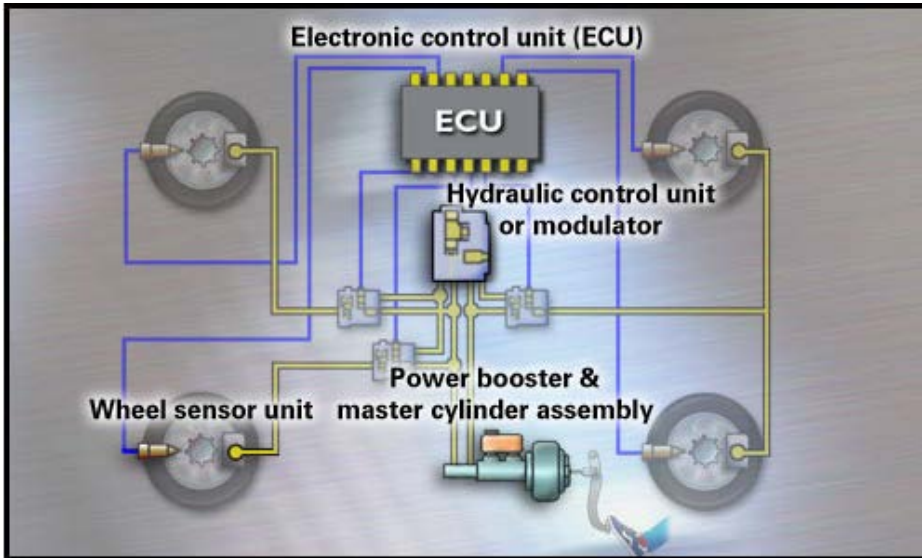

Figure 2-Electronic control unit (ECU)

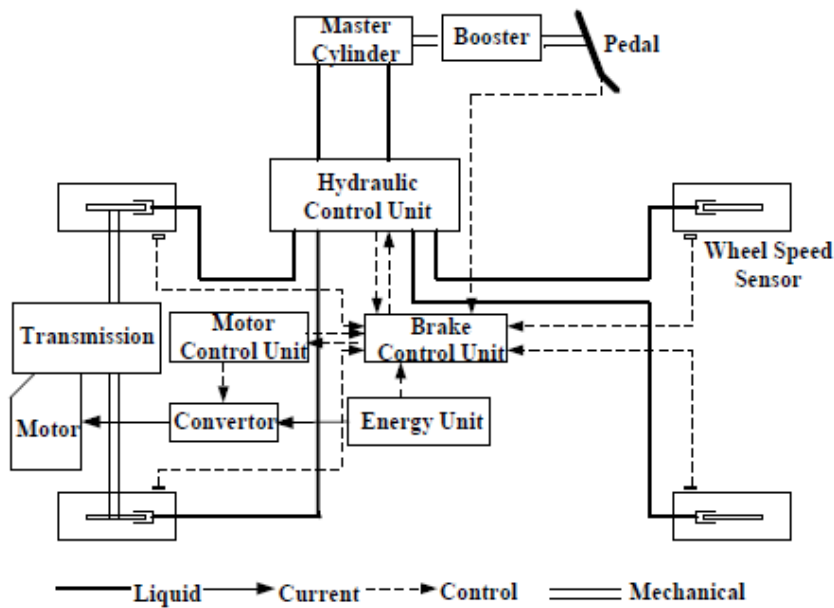

Figure 3-Configuration of the braking control system.

Braking force and the tendency of the wheels to lock up are affected by a combination of factors such as the friction coefficient of the road surface, and the difference between the vehicle speed and the road wheel speed. The ABS prevents the road wheels from locking up during heavy braking by controlling the vehicle's brake system hydraulic pressure.

During normal braking, as the rotational speed of the wheel falls, no electric current flows from the ECU to the hydraulic unit. The solenoid valve is not energized. The brake master cylinder hydraulic pressure is applied to the brake unit, and the ABS is not involved. However, even though the ABS is passive during normal braking, its control module is constantly monitoring for rapid deceleration of any of the wheels.

If a wheel-speed sensor signals severe wheel deceleration - which means the wheel is likely to lock up - the ECU sends a current to the hydraulic unit. This energizes the solenoid valve. The action of the valve isolates the brake circuit from the master cylinder. This stops the braking pressure at that wheel from rising, and keeps it constant.

If the sensors signal the wheel is still decelerating too rapidly, the ECU sends a larger current to the hydraulic unit. The armature moves even further and opens the valve. It opens a passage from the brake circuit. Brake fluid is sent from the brake circuit back to the master cylinder. Pressure in the brake caliper circuit is reduced so that the wheel is braked less heavily.

If the wheel sensors indicate that lowering the brake pressure is letting the wheel accelerate again, the ECU stops sending current to the hydraulic unit and de-energizes the solenoid valve. This lets the pressure increase, so that the wheel is again decelerated.

This cycle repeats itself about four to six times per second.

It is normal in an ABS for the valves in the hydraulic control unit to keep changing position as they change the brake pressure that's being applied. These changes in position may cause rapid pulsations to be felt through the brake pedal.

### **3 Example of an ABS control cycle**

The values recorded relate to the control cycle of one wheel. The initial vehicle speed is 80 km/h.

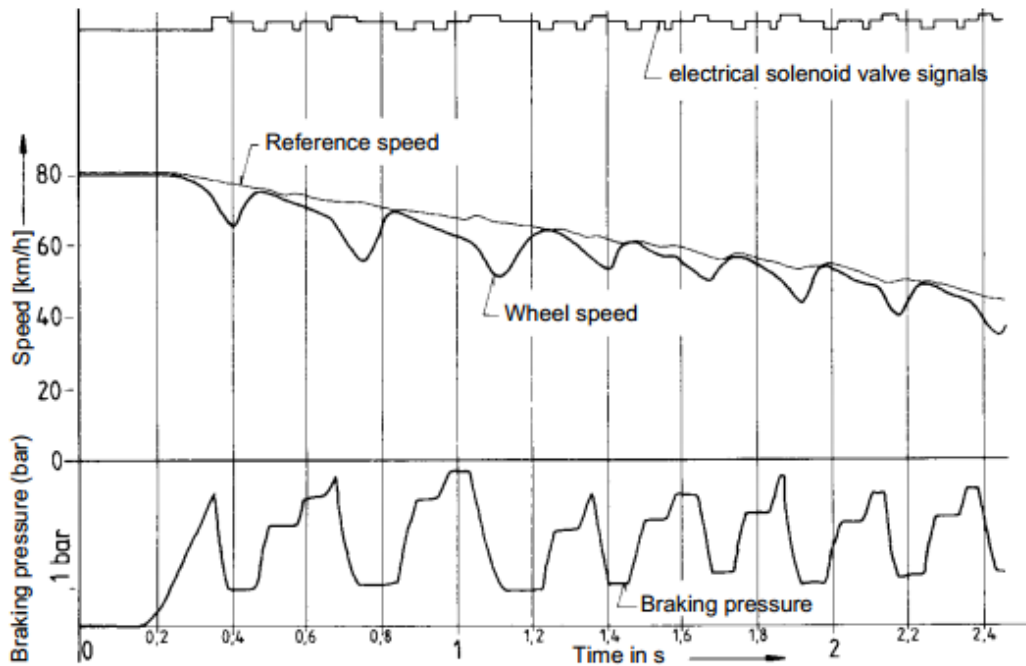

Figure 4- The process of ABS

On the abscissa, the control cycles are recorded relative to time. In the area of the ordinate, the braking pressure is shown in the bottom section and the middle section shows the reference and wheel speeds. Fig. 4. [4]

## REFIRENCE

- 1 .Jingang Guo; Xiaoping Jian and Guangyu Lin; Performance Evaluation of an Anti-Lock Braking System for Electric Vehicles with a Fuzzy Sliding Mode Controller; 2014
- 2 .Lin, C.M.; Hsu, C.F. Neural-network hybrid control for antilock braking systems. IEEE Trans. Neural Netw. Learn. Syst. 2003, 14, 351–359.
3. Yu, J.S. A robust adaptive wheel-slip controller for antilock brake system. In Proceedings of the 36th IEEE Conference on Decision and Control, San Diego, CA, USA, 10–12 December 1997; Volume 3, pp. 2545–2546.
4. M.Sc.Alen Marozka, Yury Petrenko; Structure Development And Simulation Of Plug-in Hybrid Electric Vehicle. Системный анализ и прикладная информатика, 2013, 1-2, С.2309-4923.